

COMBAT HELMET

BATSKIN hellbender™

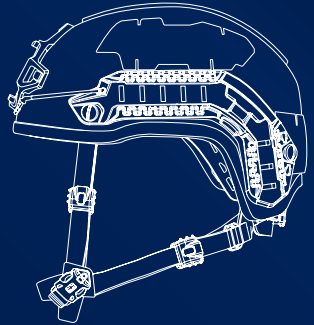
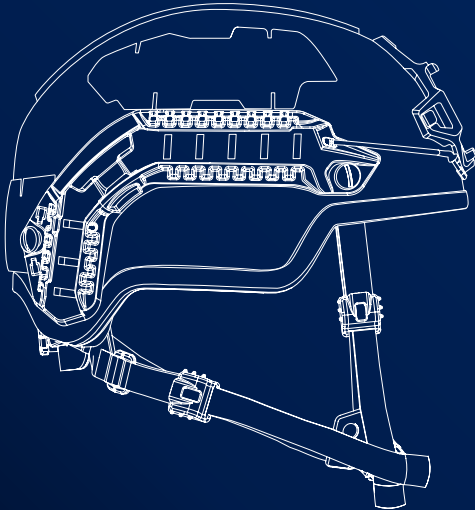

HELLBENDER HELMET SYSTEM INSTRUCTION GUIDE

BATLSKIN HELLBENDER HEAD PROTECTION SYSTEM

TO THE OPERATOR – Duty calls and no matter the pace, obstacle or environment, your command wants you to be ready for whatever your mission throws at you. The Batlskin® Hellbender™ helmet combines the performance of the Advanced Combat Helmet (ACH) with an enhanced shell geometry that provides increased ballistic protection. Manufactured to meet stringent quality and performance standards, the scalable Hellbender helmet is purpose-built to give you peace of mind – so you can focus on your mission.

GALVION. EMPOWER YOUR MISSION.

PLEASE BE SURE TO READ ALL INSTRUCTIONS AND FOLLOW ALL WARNINGS. POOR SET-UP AND ADJUSTMENT MAY COMPROMISE THE SYSTEMS ABILITY TO PROVIDE THE PROTECTION THAT IT IS DESIGNED TO DELIVER DURING A BLUNT FORCE OR BALLISTIC IMPACT. WARRANTY AND WARNING INFORMATION CAN BE FOUND BY SCANNING THE QR CODE.



HAVE QUESTIONS OR COMMENTS? CONTACT GALVION CUSTOMER SUPPORT

1-866-713-0406 | CUSTOMERCARE@GALVION.COM | GALVION.COM

CONTENTS

This manual provides information regarding the components of your Batlskin Hellbender Head Protection System. The Hellbender helmet is an upgradable platform for future capability enhancements. It is important to follow the instructions regarding the adjustment of your head protection system. Poor adjustment and over tightening of bolts may compromise the system's ability to provide the protection it is designed to deliver.

HELMET ANATOMY		FIT & CUSTOMIZATION		ACCESSORY COMPATIBILITY	
Hellbender Helmet	4	Sizing	7	Shroud	12
APEX Liner	5	How to measure head size	7	Rails	13
Rails	6	Helmet	8	Rail Adapters	14
		Adjusting Retention System	9	Helmet Cover	15
		Adjusting Fitband System	11	Headset Integration	16
				Headset Integration (Rail)	17
				Spare Parts	18
				Care & Support	21

HELLBENDER HELMET

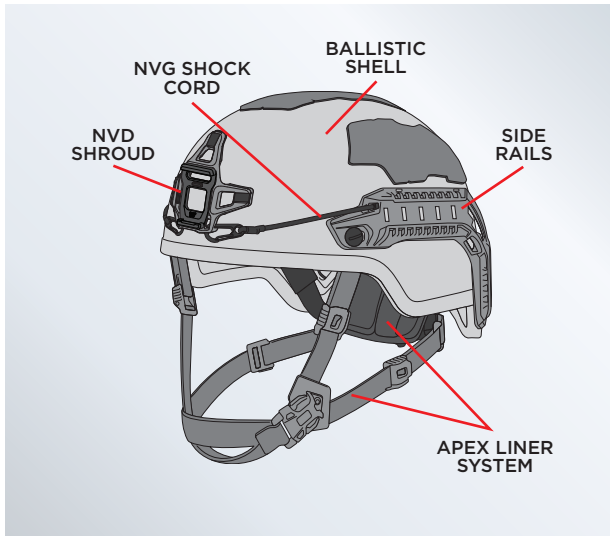

APEX LINER

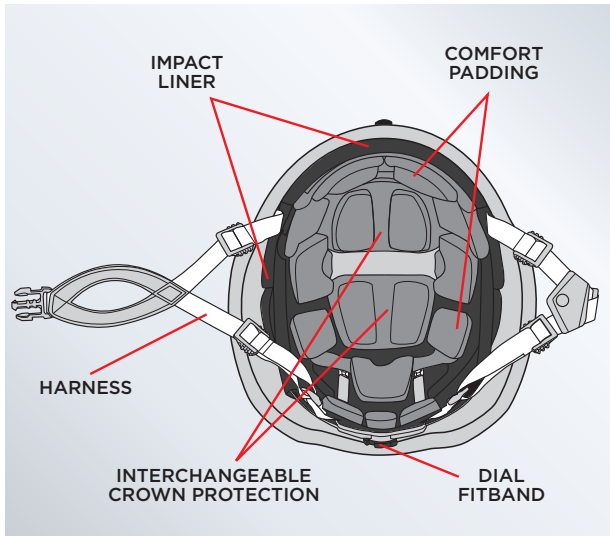

RAILS

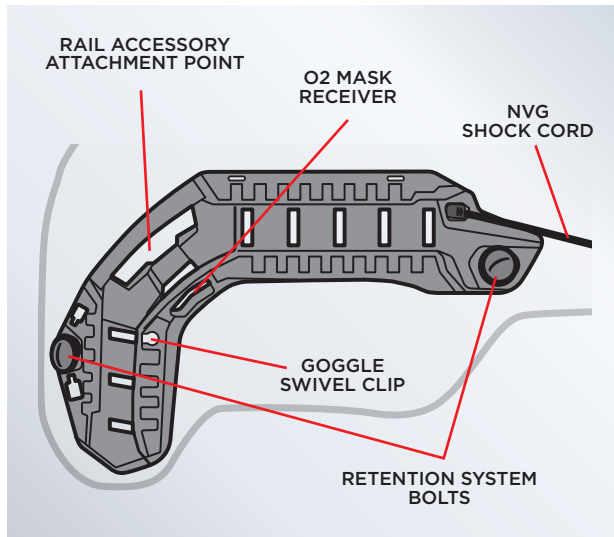

Rails are one size.

SIZING - HOW TO MEASURE HEAD SIZE

User will obtain the most accurate head measurements using a tape measure for circumference and a caliper for length and width.

Evaluate size while wearing the typical, everyday headwear, hairstyle, head coverings, etc., worn with helmet.

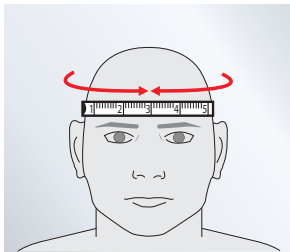

Using a measuring tape at approximately $\frac{1}{2}$ " above eyebrows and ears, measure head **CIRCUMFERENCE**.

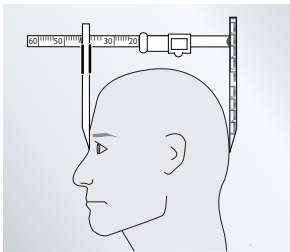

In the absence of a caliper, use 2 pencils. Hold one pencil between eyebrows and one at the back of head. An extra set of hands is important to ensure pencils are straight. Measure distance between pencils - this is the **LENGTH** measurement.

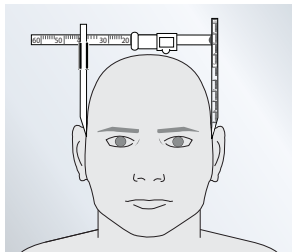

In the absence of a caliper, use 2 pencils. Hold one pencil at either side of head above ears. An extra set of hands is important to ensure pencils are straight. Measure distance between pencils - this is the **WIDTH** measurement.

SIZING - HELMET

- Most users will fit into 2 helmet sizes based on head circumference only. Start there and refine using length. Use width measurements as needed.
- Be sure to also evaluate fit with additional equipment (headset, cold weather gear, eye protection, etc.) as these will all affect the amount of space needed in helmet.
- With use, liners get worn in and compressed or stretched, and helmet may feel larger so make sure to have snug fit when trying on with new liner system.

SIZING CHART		CIRCUMFERENCE	LENGTH	WIDTH
SMALL	inch	< 22 ½	< 7 ¼	< 6
	mm	< 570	< 185	< 155
MEDIUM	inch	21 ¾ - 23 ¼	7 - 7 ⅞	5 ⅜ - 6 ½
	mm	540 - 590	180 - 200	135 - 165
LARGE	inch	22 - 24 ¼	7 ⅝ - 8 ½	5 ½ - 6 ¾
	mm	560 - 615	195 - 215	140 - 170
X-LARGE	inch	23 ¼ - 25 ⅝	8 ¼ - 9	5 ⅞ - 7
	mm	590 - 650	210 - 230	150 - 180

ADJUSTING RETENTION SYSTEM

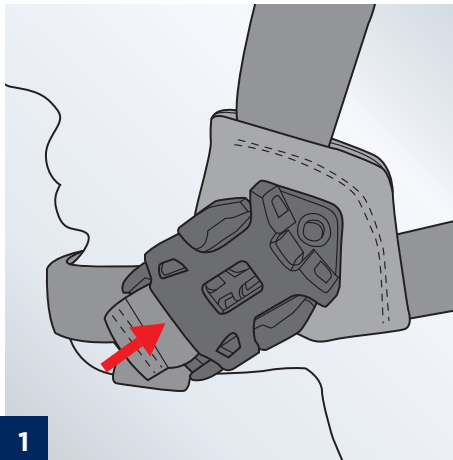

1 Buckle chinstrap.

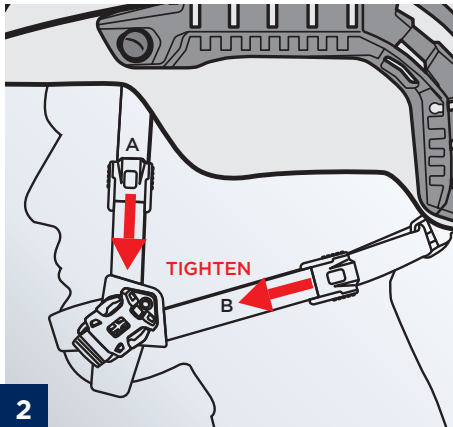

- 2
- Users may find it easier to adjust tensioners on both left and right side of harness at the same time.
- A.** Unlock front tensioners and tighten as needed. Lock in place.
 - B.** Unlock rear tensioners and tighten as needed. Lock in place.

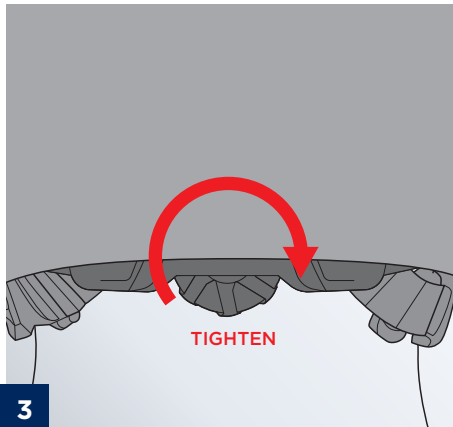

Tighten fitband by turning the dial clockwise.

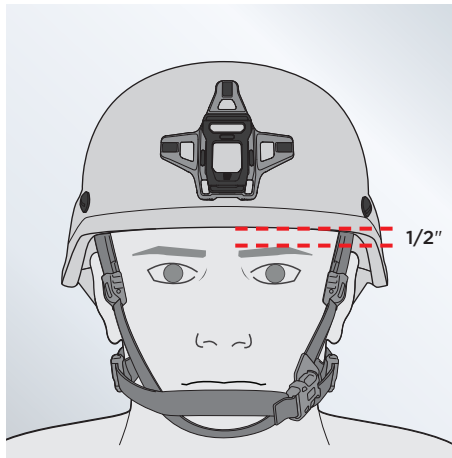

When properly adjusted, helmet should sit $\frac{1}{2}$ " above the brow.

ADJUSTING FITBAND SYSTEM

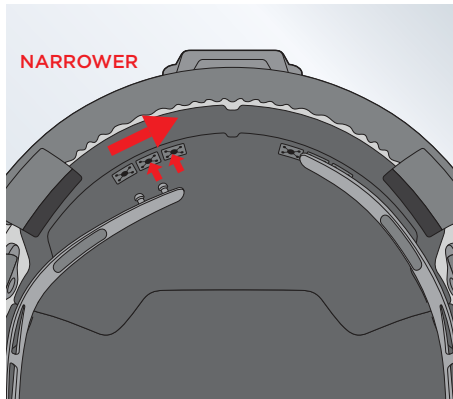

FITBAND TOO LOOSE?

Remove front comfort pad.

Snap fitband arm posts towards front of helmet for narrower fit.

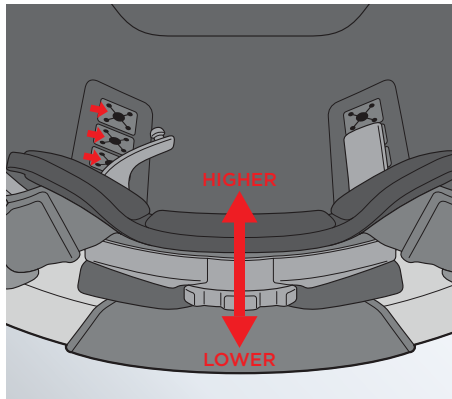

NAPE PAD

Nape pad should rest at the base of skull. Adjust higher or lower if needed.

Users may prefer a higher nape pad position for increased neck range of motion while in the prone position. Users may prefer a lower nape pad position for increased stability

SHROUD

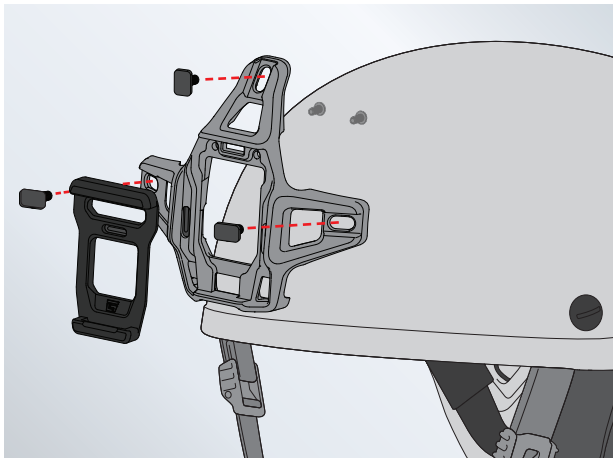

Insert hardware through shroud and secure. Position shroud so that it is level with the top of edge trim and fully tighten bolts so that shroud cannot be rotated.

RAILS

DO NOT FULLY TIGHTEN RAIL BOLTS UNTIL BOTH FRONT AND REAR ARE SECURED.

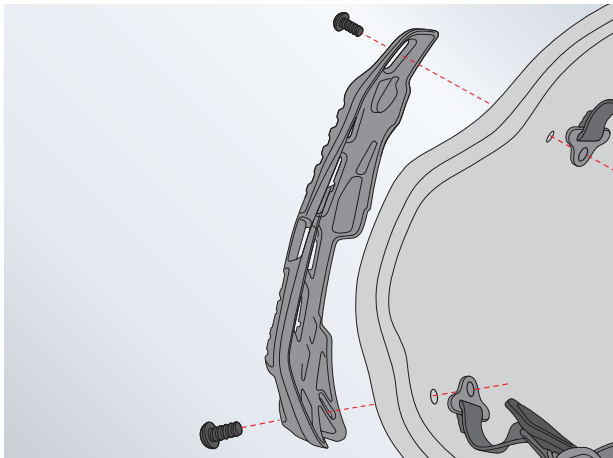

Thread bolt through rail into front helmet hole and use flathead screwdriver to tighten in strap anchor. Repeat with rear rail bolt. With rail secured, center rail over ear cup and tighten bolts so that strap anchors cannot rotate.

RAIL ADAPTERS

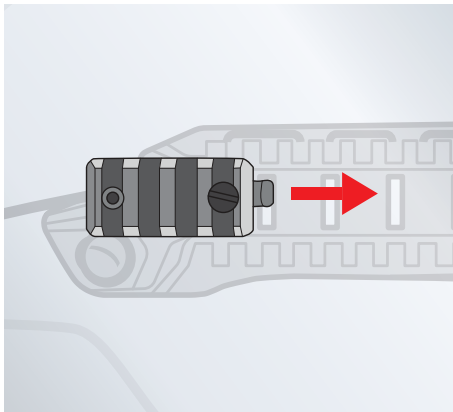

PICATINNY RAIL ADAPTER

Squeeze the end tab and slide the adapter onto rail channel tab-first. Once in the preferred position, release the tab and tighten the screw to secure the adapter in place.

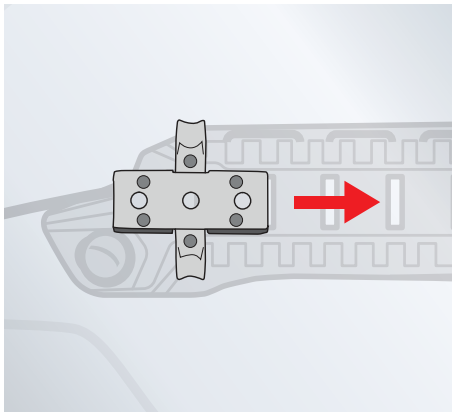

CROSS BASE RAIL ADAPTER

Attach the desired accessory onto the rail adapter. Tighten screws provided with the accessory to secure it in place. Pinch the tabs on either side of the adapter and slide onto rail. Release the tabs when in the preferred position.

HELMET COVER

(Ordered Separately)

HELMET COVER DESIGNS VARY

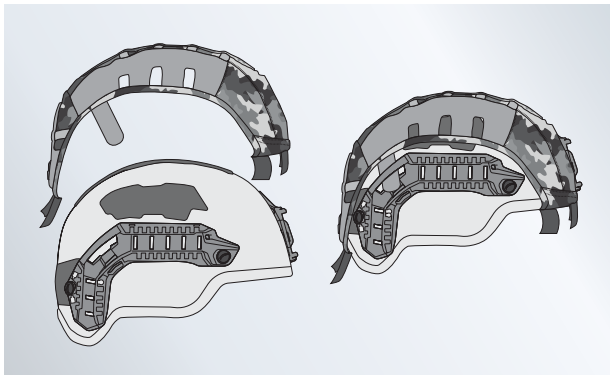

1. Align the front hole in the helmet cover with the mount of the helmet.
2. Pull cover over helmet shell, ensuring seams of cover are symmetrical and there are minimal ripples in the fabric.
3. Pull loop tabs tightly over helmet edge and adhere to hook dots already installed in helmet. The loop tabs should not cover any holes in helmet.

HEADSET INTEGRATION

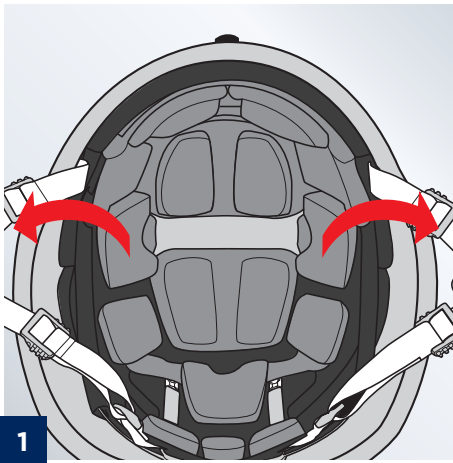

Remove side comfort pads if needed, to make space for the headset band.

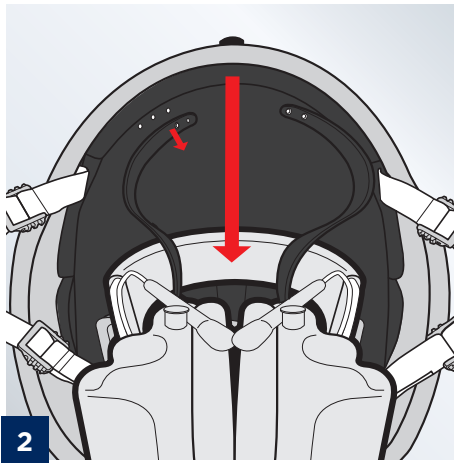

(OPTIONAL) To make helmet and headset a single unit: Remove front comfort pads, and weave headset through fitband arms. Re-attach fitband arms, re-install front comfort pads.

HEADSET INTEGRATION (RAIL)

(Ordered Separately)

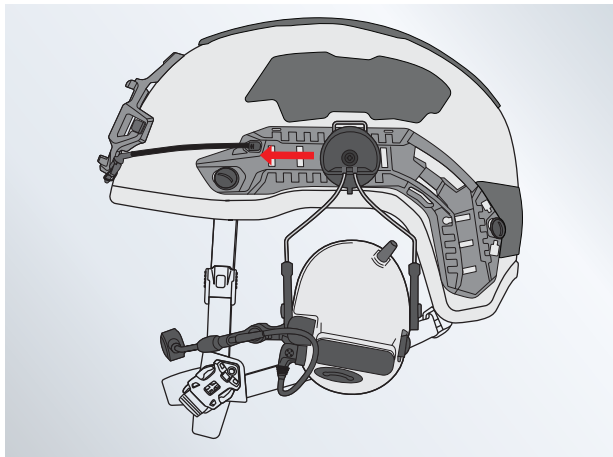

Slide adapter into desired position. Store cup-to-cup wire in helmet cover or inside helmet as desired.

SPARE PARTS

(Ordered Separately)

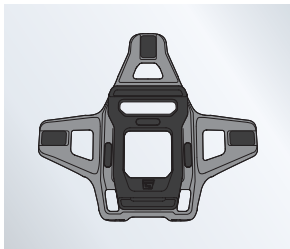

SHROUD

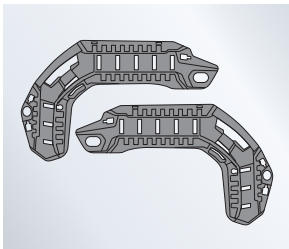

RAILS



NVG BUNGEE KIT



APEX LINER

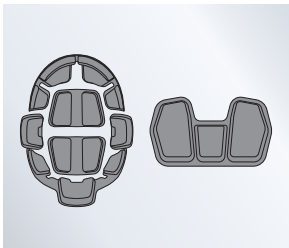

THICK COMFORT PADS

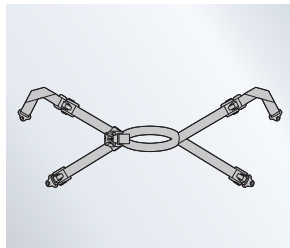

HARNES

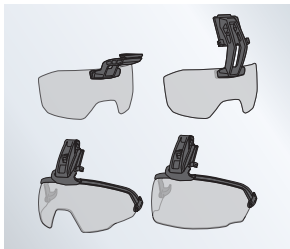

VISORS

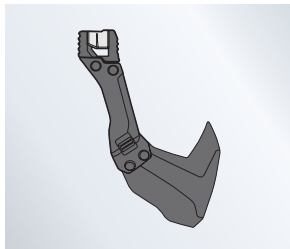

MANDIBLE

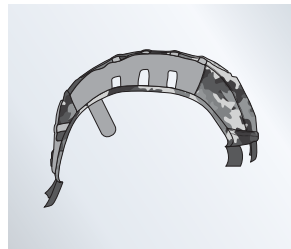

HELMET COVERS

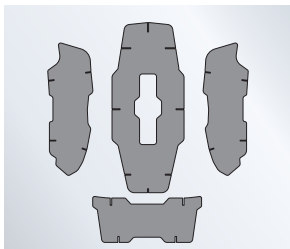

EXTERNAL LOOP KIT

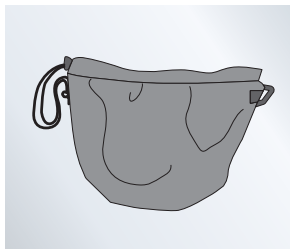

CARRY BAG

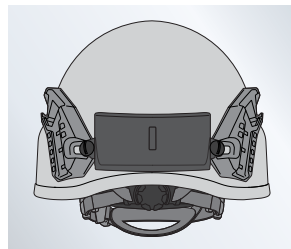

COUNTERWEIGHT

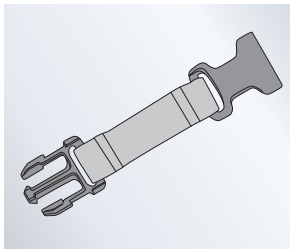

CBRN EXTENDER

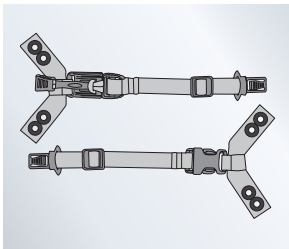

O2 STRAP EXTENDER

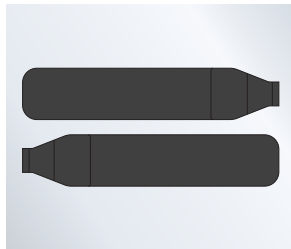

ACCESSORY STRAPS

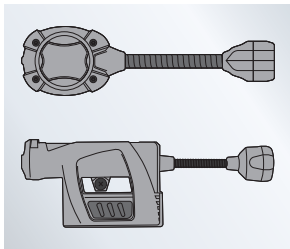

TASK LIGHTS

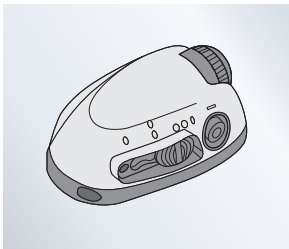

STROBE

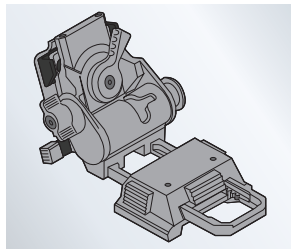

G24 NVG MOUNT

CARE & SUPPORT

ONE-TIME EVENTS

If a severe impact damages the helmet resulting in dented or flattened areas, the helmet performance might be reduced. The helmet system should be replaced.

HELMET COVER CAN BE WORN TO MINIMIZE WEAR AND TEAR ON THE HELMET SHELL LOOP AND PAINT.

RECOMMENDED MAINTENANCE: ALL USERS

1. Clean the helmet with a mild soap and water
2. Check that the retention system bolts are tight
3. Clean the Loop to remove dust and dirt by using air pressure
4. Visually check the shroud and rails for signs of breakage
5. Visually check the fit band for signs of breakage
6. Check that the rear dial on the fit band works properly
7. Check that the retention system does not have any damage, that the buckle and strap tensioners open and close properly

IF ANY DEFECTS ARE DETECTED, THE DAMAGED COMPONENTS MUST BE REPLACED BEFORE USE.

HAVE QUESTIONS OR COMMENTS? CONTACT GALVION CUSTOMER SUPPORT

1-866-713-0406 | CUSTOMERCARE@GALVION.COM | GALVION.COM



©2026 GALVION INC. ALL RIGHTS RESERVED. GALVION™, BATLSKIN® AND BATLSKIN HELLBENDER™ ARE TRADEMARKS OF GALVION INC. OR ONE OF ITS AFFILIATES.
5-0735-0000 REV B GAL3258_0226